

UNIT:mm

REVISION	DATE	DESCRIPTION	REVISED
000			

ISSUE DATE	SCALE	APPROVED	NAME
2024/08/20	1:2	Y.MOTOIE	HPR2-DV4SM8シリーズ共通外観図
	SHEET SIZE	CHECKED	DRAWING NAME
	A3	M.TAKEGAMI	外観図_Outline
	PROJECTION	DESIGNED	DRAWING No.
		A.MATSUMURA	UA45229-G
		DRAWN	REVISION
		A.MATSUMURA	000
			01/03

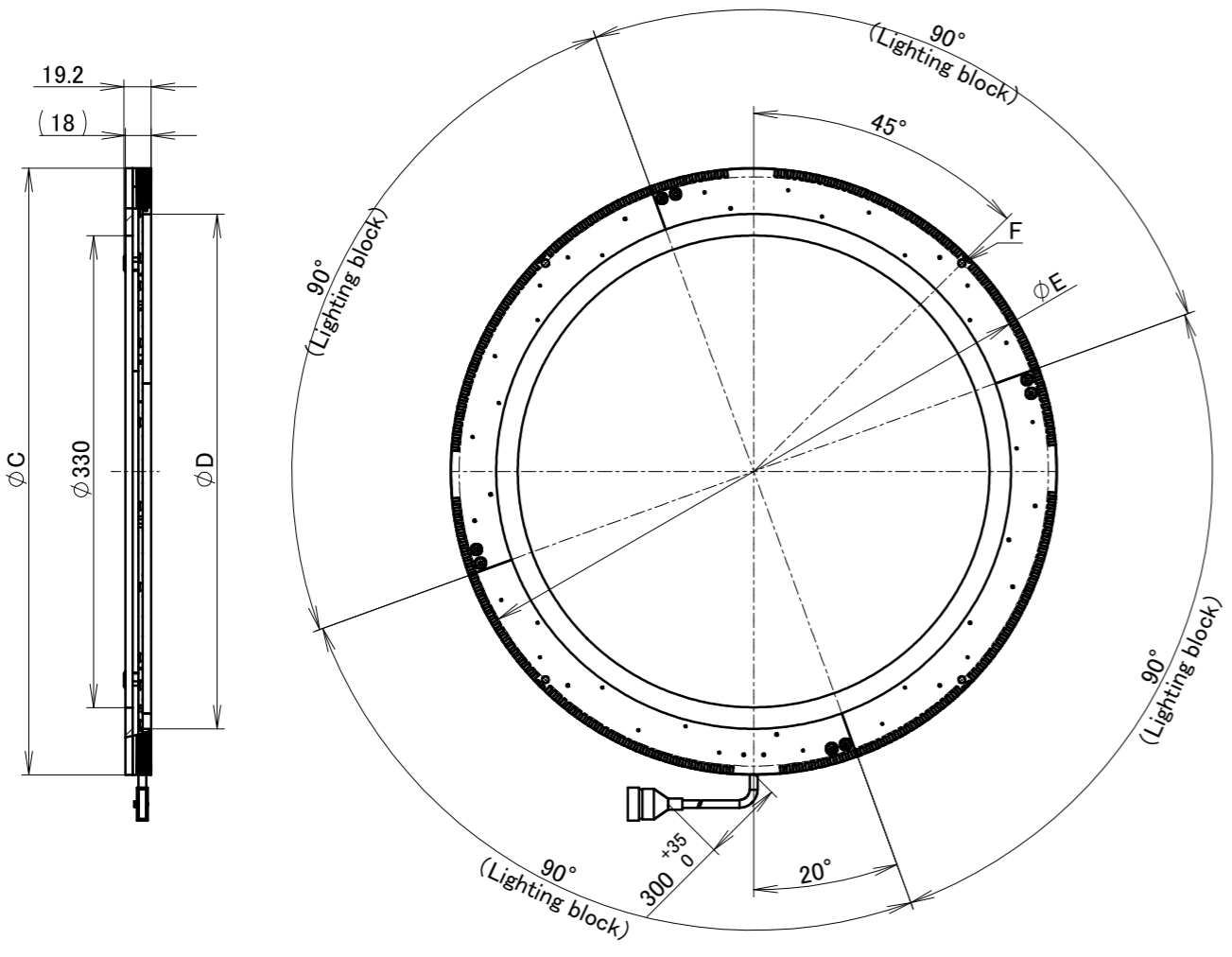

<shape 5>

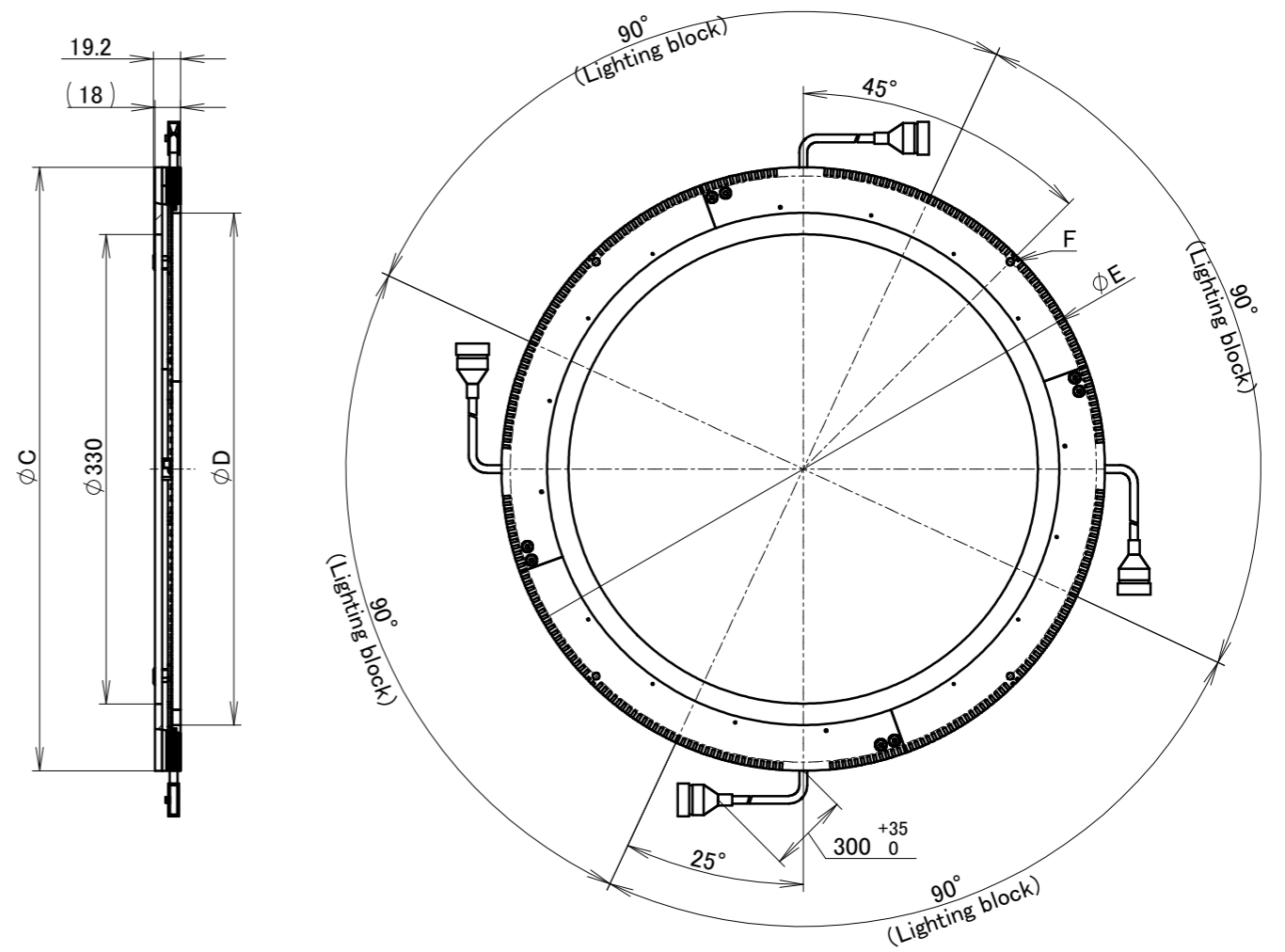

<shape 6>

UNIT:mm

REVISION	DATE	DESCRIPTION	REVISED
000			

ISSUE DATE	SCALE	APPROVED	NAME
2024/08/20	1:5	Y.MOTOIE	HPR2-DV4SM8シリーズ共通外観図
	SHEET SIZE	CHECKED	DRAWING NAME
	A3	M.TAKEGAMI	外観図_Outline
	PROJECTION	DESIGNED	DRAWING No.
		A.MATSUMURA	UA45229-G
		DRAWN	REVISION
		A.MATSUMURA	000
			SHEET
			02
			03



A
B
C
D
E
F

Model	LED Color	Power Consumption	Mass (Approx.)	A	B	C	D	E	F	Number of cables	Connector	shape
HPR2-50XX-DV4SM8	RD	7.20W(1.8W x 4)	0.060kg	18	17.5	50	18	45	4 x M3 x 4	1	SMR-08V-B ①: CH1(+) ②: CH1(-) ③: CH2(+) ④: CH2(-) ⑤: CH3(+) ⑥: CH3(-) ⑦: CH4(+) ⑧: CH4(-)	1
	SW	8.16W(2.04W x 4)										
	FC	3.46W (R:0.288W x 4 = 1.152W) (G:0.288W x 4 = 1.152W) (B:0.288W x 4 = 1.152W)	0.120kg							4	SMR-08V-B ①: R(+) ②: R(-) ③: G(+) ④: G(-) ⑤: B(+) ⑥: B(-) ⑦: NC ⑧: NC	2
HPR2-75XX-DV4SM8	RD	15.9W(3.96W x 4)	0.160kg	26.4	25.5	91	41	83	4 x M4 x 5	1	SMR-08V-B ①: CH1(+) ②: CH1(-) ③: CH2(+) ④: CH2(-) ⑤: CH3(+) ⑥: CH3(-) ⑦: CH4(+) ⑧: CH4(-)	3
	SW	14.4W(3.6W x 4)										
	FC	8.16W (R:0.408W x 4 = 1.632W) (G:0.816W x 4 = 3.264W) (B:0.816W x 4 = 3.264W)	0.260kg							4	SMR-08V-B ①: R(+) ②: R(-) ③: G(+) ④: G(-) ⑤: B(+) ⑥: B(-) ⑦: NC ⑧: NC	4
HPR2-100XX-DV4SM8	RD	16.4W(4.08W x 4)	0.200kg	26.4	25.5	116	66	108	4 x M4 x 5	1	SMR-08V-B ①: CH1(+) ②: CH1(-) ③: CH2(+) ④: CH2(-) ⑤: CH3(+) ⑥: CH3(-) ⑦: CH4(+) ⑧: CH4(-)	3
	SW	21.2W(5.28W x 4)										
	FC	10.4W (R:0.864W x 4 = 3.456W) (G:0.864W x 4 = 3.456W) (B:0.864W x 4 = 3.456W)	0.340kg							4	SMR-08V-B ①: R(+) ②: R(-) ③: G(+) ④: G(-) ⑤: B(+) ⑥: B(-) ⑦: NC ⑧: NC	4
HPR2-150XX-DV4SM8	RD	25.5W(6.36W x 4)	0.260kg	26.4	25.5	166	116	158	4 x M4 x 5	1	SMR-08V-B ①: CH1(+) ②: CH1(-) ③: CH2(+) ④: CH2(-) ⑤: CH3(+) ⑥: CH3(-) ⑦: CH4(+) ⑧: CH4(-)	3
	SW	25.0W(6.24W x 4)										
	FC	13.9W (R:0.864W x 4 = 3.456W) (G:1.296W x 4 = 5.184W) (B:1.296W x 4 = 5.184W)	0.380kg							4	SMR-08V-B ①: R(+) ②: R(-) ③: G(+) ④: G(-) ⑤: B(+) ⑥: B(-) ⑦: NC ⑧: NC	4
HPR2-200XX-DV4SM8	RD	31.7W(7.92W x 4)	0.320kg	26.4	25.5	216	166	208	4 x M4 x 5	1	SMR-08V-B ①: CH1(+) ②: CH1(-) ③: CH2(+) ④: CH2(-) ⑤: CH3(+) ⑥: CH3(-) ⑦: CH4(+) ⑧: CH4(-)	3
	SW	38.4W(9.6W x 4)										
	FC	17.5W (R:1.188W x 4 = 4.752W) (G:1.584W x 4 = 6.336W) (B:1.584W x 4 = 6.336W)	0.480kg							4	SMR-08V-B ①: R(+) ②: R(-) ③: G(+) ④: G(-) ⑤: B(+) ⑥: B(-) ⑦: NC ⑧: NC	4
HPR2-250XX-DV4SM8	RD	42.3W(10.56W x 4)	0.440kg	26.4	25.5	266	210	258	4 x M4 x 5	1	SMR-08V-B ①: CH1(+) ②: CH1(-) ③: CH2(+) ④: CH2(-) ⑤: CH3(+) ⑥: CH3(-) ⑦: CH4(+) ⑧: CH4(-)	3
	SW	43.2W(10.8W x 4)										
	FC	22.5W (R:1.296W x 4 = 5.184W) (G:2.16W x 4 = 8.64W) (B:2.16W x 4 = 8.64W)	0.560kg							4	SMR-08V-B ①: R(+) ②: R(-) ③: G(+) ④: G(-) ⑤: B(+) ⑥: B(-) ⑦: NC ⑧: NC	4
HPR2-400XX-DV4SM8	RD	42.3W(10.56W x 4)	1.1kg	19.2	18	424	360	412	4 x M6 x 6	1	SMR-08V-B ①: CH1(+) ②: CH1(-) ③: CH2(+) ④: CH2(-) ⑤: CH3(+) ⑥: CH3(-) ⑦: CH4(+) ⑧: CH4(-)	5
	SW	43.2W(10.8W x 4)										
	FC	27.7W (R:1.728W x 4 = 6.912W) (G:2.592W x 4 = 10.368W) (B:2.592W x 4 = 10.368W)	1.2kg							4	SMR-08V-B ①: R(+) ②: R(-) ③: G(+) ④: G(-) ⑤: B(+) ⑥: B(-) ⑦: NC ⑧: NC	6

UNIT:mm

000			
REVISION	DATE	DESCRIPTION	REVISED

ISSUE DATE	SCALE	APPROVED	NAME
2024/08/20	1:5	Y.MOTOIE	HPR2-DV4SM8シリーズ共通外観図
	SHEET SIZE	CHECKED	DRAWING NAME
	A3	M.TAKEGAMI	外観図_Outline
	PROJECTION	DESIGNED	
		A.MATSUMURA	DRAWING No.
		DRAWN	UA45229-G
		A.MATSUMURA	REVISION
			000
			03/03

